

UNF Unified Fine Threads
 Unified Grobgewinde
 UNF
 Unificato passo fine

Machine taps
 Maschinengewindebohrer

- ▶ High performance on various ductile materials
- ▶ Specially designed to prevent oversized threads and reduce gauging problems

- ▶ Ausgezeichnete Leistung bei verschiedenen Werkstoffen.
- ▶ Speziell entwickelt, um zu große Gewindedurchmesser zu vermeiden und Messprobleme zu reduzieren.

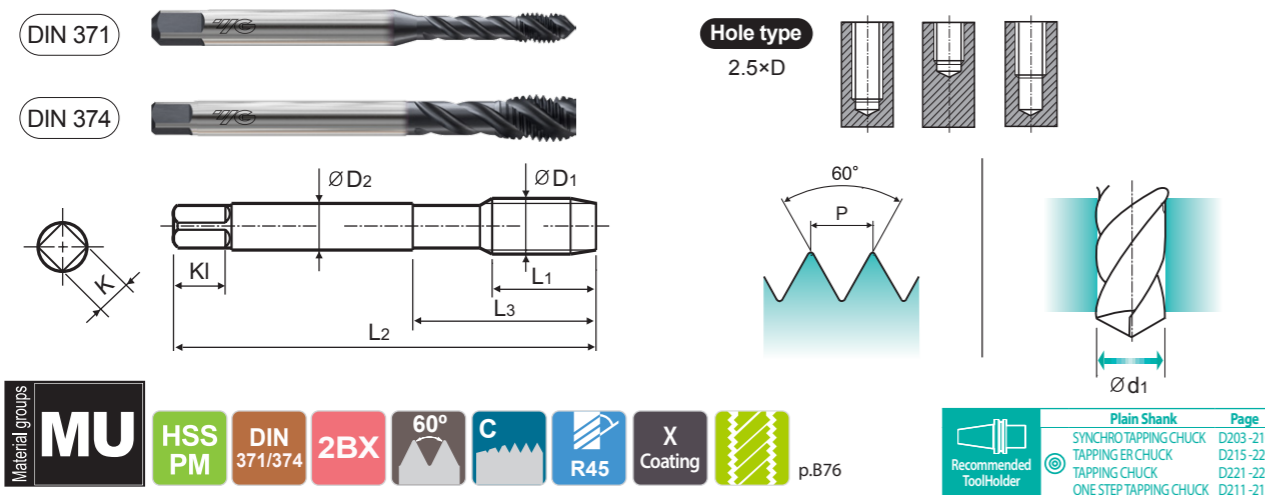

SIZE	TPI	EDP No.	Thread Length	Overall Length	Neck Length	Shank Diameter	Square Size	Square Length	No. of Flute	Tapping Drill Diameter
ØD1		X-coating	L1	L2	L3	ØD2	K	KI	Z	Ød1
#4 - 48 UNF		TRE33182GS	5.1	56.0	18.0	3.5	2.7	6.0	2	2.40
#5 - 44 UNF		TRE33222GS	5.1	56.0	18.0	3.5	2.7	6.0	3	2.70
#6 - 40 UNF		TRE33262GS	6.4	56.0	20.0	4.0	3.0	6.0	3	2.90
#8 - 36 UNF		TRE33302GS	6.4	63.0	21.0	4.5	3.4	6.0	3	3.50
#10 - 32 UNF		TRE33342GS	8.5	70.0	25.0	6.0	4.9	8.0	3	4.10
#12 - 28 UNF		TRE33382GS	8.5	80.0	30.0	6.0	4.9	8.0	3	4.60
1/4 - 28 UNF		TRE33422GS	10.2	80.0	30.0	7.0	5.5	8.0	3	5.50
5/16 - 24 UNF		TRE33462GS	10.6	90.0	35.0	8.0	6.2	9.0	3	6.90
3/8 - 24 UNF		TRE33502GS	10.6	100.0	39.0	9.0	7.0	10.0	3	8.50
7/16 - 20 UNF		TRE33542GS	12.7	100.0	40.0	8.0	6.2	9.0	3	9.90
1/2 - 20 UNF		TRE33582GS	12.7	100.0	40.0	9.0	7.0	10.0	3	11.50
9/16 - 18 UNF		TRE33622GS	14.2	100.0	40.0	11.0	9.0	12.0	3	12.90
5/8 - 18 UNF		TRE33662GS	14.2	100.0	40.0	12.0	9.0	12.0	3	14.50
3/4 - 16 UNF		TRE33722GS	15.9	110.0	44.0	14.0	11.0	14.0	4	17.50
7/8 - 14 UNF		TRE33762GS	18.2	125.0	50.0	18.0	14.5	17.0	4	20.50
1 - 12 UNF		TRE33802GS	21.2	140.0	54.0	20.0	16.0	19.0	4	23.20

▶ DIN 371(#4~3/8) and DIN 374(7/16~1)

◎ : Excellent ○ : Good

ISO Material Description	P										M				K					
	Non-alloy steel					Low alloy steel					High alloyed steel, and tool steel		Stainless steel		Grey cast iron		Nodular cast iron		Malleable cast iron	
VDI 3323	1	2	3	4	5	6	7	8	9	10	11	12	13	14	15	16	17	18	19	20
HRc	13	25	28	32	30	10	29	32	38	15	35	15	23	10	10	26	3	25	21	21
HB	125	190	250	270	300	180	275	300	350	200	325	200	240	180	180	260	160	250	130	230
Recommended	○	◎	◎	◎	◎	◎	◎	◎	◎	◎	◎	◎	◎	◎	◎	◎	◎	◎	◎	◎

ISO Material Description	N					S					H										
	Aluminum-wrought alloy		Aluminum-cast, alloyed		Copper and Copper Alloys (Bronze / Brass)	Non Metallic Materials			Heat Resistant Super Alloys		Titanium Alloys		Hardened steel	Chilled Cast Iron	Hardened Cast Iron						
VDI 3323	21	22	23	24	25	26	27	28	29	30	31	32	33	34	35	36	37	38	39	40	41
HRc	21	22	23	24	25	26	27	28	29	30	31	32	33	34	35	36	37	38	39	40	41
HB	60	100	75	90	130	110	90	100			200	280	250	350	320	400Rm	1050Rm	550	630	400	550
Recommended	○	○	◎	◎	◎	◎	◎	◎			◎	◎	◎	◎	◎	◎	◎	◎	◎	◎	◎

M ISO Metric Coarse Threads DIN 13
 Metrisches ISO-Gewinde DIN 13
 ISO MÉTRIQUE DIN13
 ISO Metrico passo grosso DIN 13

Machine taps
 Maschinengewindebohrer

- ▶ High performance on various ductile materials
- ▶ Specially designed to prevent oversized threads and reduce gauging problems

- ▶ Ausgezeichnete Leistung bei verschiedenen Werkstoffen.
- ▶ Speziell entwickelt, um zu große Gewindedurchmesser zu vermeiden und Messprobleme zu reduzieren.

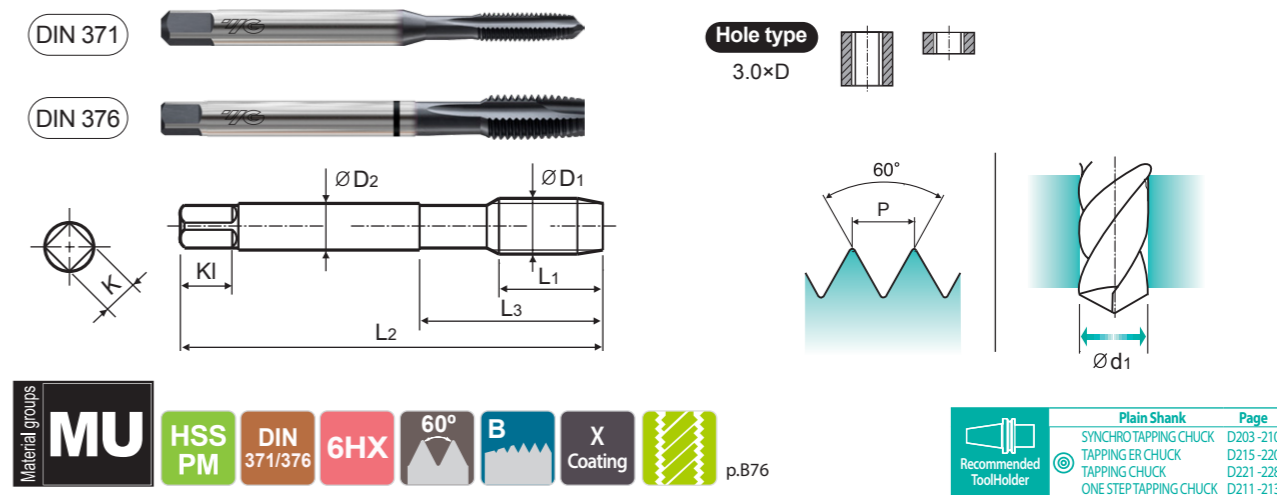

SIZE	Pitch	EDP No.	Thread Length	Overall Length	Neck Length	Shank Diameter	Square Size	Square Length	No. of Flute	Tapping Drill Diameter
ØD1	P	X-coating	L1	L2	L3	ØD2	K	KI	Z	Ød1
M2 x 0.4		TRJ15136GS	8.0	45.0	13.0	2.8	2.1	5.0	2	1.6
M2.5 x 0.45		TRJ15176GS	9.0	50.0	15.0	2.8	2.1	5.0	2	2.1
M3 x 0.5		TRJ15206GS	11.0	56.0	18.0	3.5	2.7	6.0	3	2.5
M3.5 x 0.6		TRJ15226GS	12.0	56.0	20.0	4.0	3.0	6.0	3	2.9
M4 x 0.7		TRJ15246GS	13.0	63.0	21.0	4.5	3.4	6.0	3	3.3
M5 x 0.8		TRJ15286GS	15.0	70.0	25.0	6.0	4.9	8.0	3	4.2
M6 x 1.0		TRJ15316GS	17.0	80.0	30.0	6.0	4.9	8.0	3	5.0
M7 x 1.0		TRJ15346GS	17.0	80.0	30.0	7.0	5.5	8.0	3	6.0
M8 x 1.25		TRJ15366GS	20.0	90.0	35.0	8.0	6.2	9.0	3	6.8
M9 x 1.25		TRJ15396GS	20.0	90.0	35.0	9.0	7.0	10.0	3	7.8
M10 x 1.5		TRJ15426GS	22.0	100.0	39.0	10.0	8.0	11.0	3	8.5
M12 x 1.75		TRJ15506GS	24.0	110.0	44.0	9.0	7.0	10.0	3	10.3
M14 x 2.0		TRJ15546GS	26.0	110.0	44.0	11.0	9.0	12.0	3	12.0
M16 x 2.0		TRJ15606GS	27.0	110.0	44.0	12.0	9.0	12.0	3	14.0
M18 x 2.5		TRJ15656GS	30.0	125.0	50.0	14.0	11.0	14.0	3	15.5
M20 x 2.5		TRJ15706GS	32.0	140.0	54.0	16.0	12.0	15.0	3	17.5
M22 x 2.5		TRJ15746GS	32.0	140.0	54.0	18.0	14.5	17.0	3	19.5
M24 x 3.0		TRJ15786GS	34.0	160.0	60.0	18.0	14.5	17.0	3	21.0

▶ DIN 371(M2~M10) and DIN 376(M12~M24)

◎ : Excellent ○ : Good

ISO Material Description	P										M				K					
	Non-alloy steel					Low alloy steel					High alloyed steel, and tool steel		Stainless steel		Grey cast iron		Nodular cast iron		Malleable cast iron	
VDI 3323	1	2	3	4	5	6	7	8	9	10	11	12	13	14	15	16	17	18	19	20
HRc	13	25	28	32	30	10	29	32	38	15	35	15	23	10	10	26	3	25	21	21
HB	125	190	250	270	300	180	275	300	350	200	325	200	240	180	180	260	160	250	130	230
Recommended	○	◎	◎	◎	◎	◎	◎	◎	◎	◎	◎	◎	◎	◎	◎	◎	◎	◎	◎	◎

ISO Material Description	N					S					H										
	Aluminum-wrought alloy		Aluminum-cast, alloyed		Copper and Copper Alloys (Bronze / Brass)	Non Metallic Materials			Heat Resistant Super Alloys		Titanium Alloys		Hardened steel	Chilled Cast Iron	Hardened Cast Iron						
VDI 3323	21	22	23	24	25	26	27	28	29	30	31	32	33	34	35	36	37	38	39	40	41
HRc	21	22	23	24	25	26	27	28	29	30	31	32	33	34	35	36	37	38	39	40	41
HB	60	100	75	90	130	110	90	100			200	280	250	350	320	400Rm	1050Rm	550	630	400	550
Recommended	○	○	◎	◎	◎	◎	◎	◎			◎	◎	◎	◎	◎	◎	◎	◎	◎	◎	◎