

MF ISO Metric Fine Threads DIN 13
 ● Metrisches ISO-Feingewinde DIN 13
 ○ ISO MÉTRIQUE PAS FINS DIN13
 ○ ISO Metrico passo grosso DIN 13

Machine taps
Maschinengewindebohrer

- ▶ High performance on various ductile materials
- ▶ Specially designed to prevent oversized threads and reduce gauging problems

- ▶ Ausgezeichnete Leistung bei verschiedenen Werkstoffen.
- ▶ Speziell entwickelt, um zu große Gewindedurchmesser zu vermeiden und Messprobleme zu reduzieren.

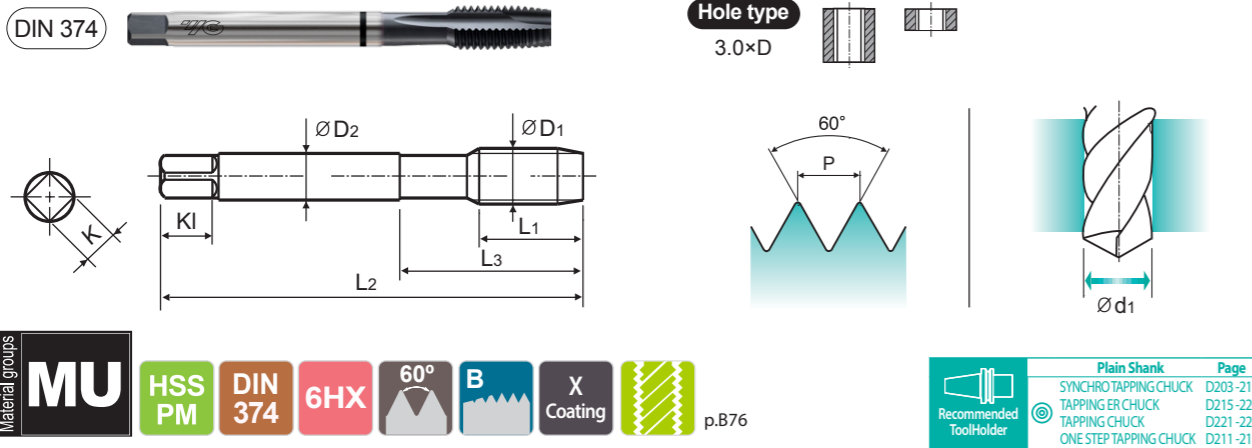

Unit : mm

SIZE	Pitch	EDP No.	Thread Length	Overall Length	Neck Length	Shank Diameter	Square Size	Square Length	No. of Flute	Tapping Drill Diameter
ØD1	P	X-coating	L1	L2	L3	ØD2	K	KI	Z	Ød1
M4 x 0.5		TRJ16256GS	10.0	63.0	21.0	2.8	2.1	5.0	3	3.5
M4 x 0.35		TRJ16696GS	10.0	63.0	21.0	2.8	2.1	5.0	3	3.7
M5 x 0.5		TRJ16296GS	11.0	70.0	25.0	3.5	2.7	6.0	3	4.5
M6 x 0.75		TRJ16326GS	13.0	80.0	30.0	4.5	3.4	6.0	3	5.3
M6 x 0.5		TRJ16336GS	13.0	80.0	30.0	4.5	3.4	6.0	3	5.5
M8 x 1.0		TRJ16376GS	17.0	90.0	36.0	6.0	4.9	8.0	3	7.0
M8 x 0.75		TRJ16386GS	14.0	80.0	30.0	6.0	4.9	8.0	3	7.3
M9 x 1.0		TRJ16406GS	20.0	90.0	36.0	7.0	5.5	8.0	3	8.0
M9 x 0.75		TRJ16416GS	17.0	80.0	36.0	7.0	5.5	8.0	3	8.3
M10 x 1.25		TRJ16436GS	22.0	100.0	40.0	7.0	5.5	8.0	3	8.8
M10 x 1.0		TRJ16446GS	18.0	90.0	36.0	7.0	5.5	8.0	3	9.0
M10 x 0.75		TRJ16456GS	18.0	90.0	36.0	7.0	5.5	8.0	3	9.3
M12 x 1.5		TRJ16516GS	22.0	100.0	40.0	9.0	7.0	10.0	3	10.5
M12 x 1.25		TRJ16526GS	22.0	100.0	40.0	9.0	7.0	10.0	3	10.8
M12 x 1.0		TRJ16536GS	18.0	100.0	40.0	9.0	7.0	10.0	3	11.0
M14 x 1.5		TRJ16556GS	22.0	100.0	40.0	11.0	9.0	12.0	3	12.5
M14 x 1.25		TRJ16566GS	22.0	100.0	40.0	11.0	9.0	12.0	3	12.8
M14 x 1.0		TRJ16576GS	18.0	100.0	40.0	11.0	9.0	12.0	3	13.0
M16 x 1.5		TRJ16616GS	22.0	100.0	40.0	12.0	9.0	12.0	3	14.5
M16 x 1.0		TRJ16626GS	18.0	100.0	40.0	12.0	9.0	12.0	3	15.0

▶ NEXT PAGE

◎ : Excellent ○ : Good

ISO Material Description	P										M				K					
	Non-alloy steel					Low alloy steel					High alloyed steel, and tool steel		Stainless steel		Grey cast iron	Nodular cast iron		Malleable cast iron		
VDI 3323	1	2	3	4	5	6	7	8	9	10	11	12	13	14	15	16	17	18	19	20
HRC	13	25	28	32	30	10	29	32	38	15	35	15	23	10	10	26	3	25	13	21
HB	125	190	250	270	300	180	275	300	350	200	325	200	240	180	180	260	160	250	130	230
Recommended	◎	◎	◎	◎	◎	◎	◎	◎	◎	◎	◎	◎	◎	◎	◎	◎	◎	◎	◎	◎

ISO Material Description	N										S						H				
	Aluminum-wrought alloy		Aluminum-cast, alloyed				Copper and Copper Alloys (Bronze / Brass)				Non Metallic Materials		Heat Resistant Super Alloys				Titanium Alloys		Hardened steel	Chilled Cast Iron	Hardened Cast Iron
VDI 3323	21	22	23	24	25	26	27	28	29	30	31	32	33	34	35	36	37	38	39	40	41
HRC	15	30	25	38	34	15	30	25	38	34	200	280	250	350	320	400Rm	1050Rm	550	630	400	550
HB	60	100	75	90	130	110	90	100													
Recommended	○	○	◎	◎	◎	◎	◎	◎													

MF ISO Metric Fine Threads DIN 13
 ● Metrisches ISO-Feingewinde DIN 13
 ○ ISO MÉTRIQUE PAS FINS DIN13
 ○ ISO Metrico passo grosso DIN 13

Machine taps
Maschinengewindebohrer

- ▶ High performance on various ductile materials
- ▶ Specially designed to prevent oversized threads and reduce gauging problems

- ▶ Ausgezeichnete Leistung bei verschiedenen Werkstoffen.
- ▶ Speziell entwickelt, um zu große Gewindedurchmesser zu vermeiden und Messprobleme zu reduzieren.

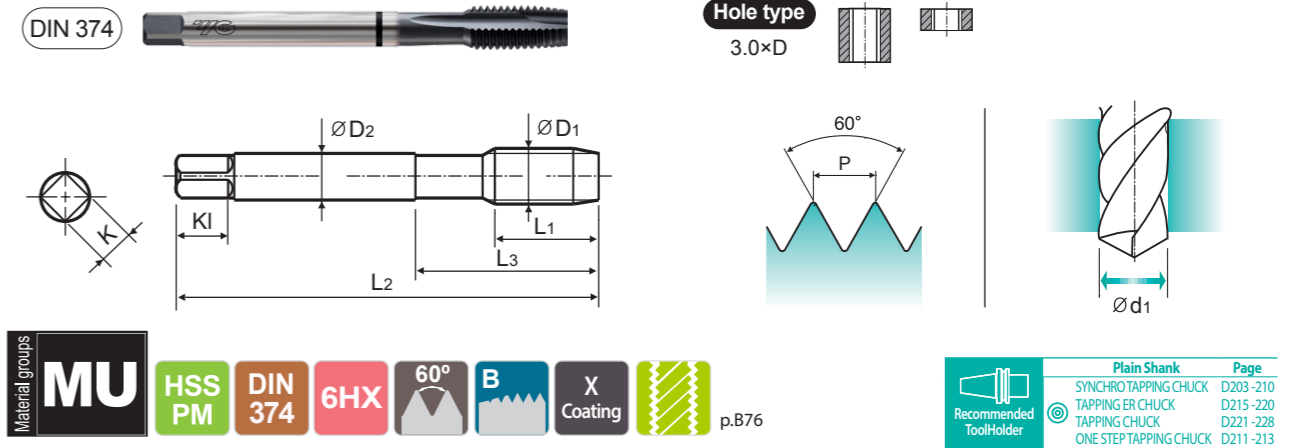

Unit : mm

SIZE	Pitch	EDP No.	Thread Length	Overall Length	Neck Length	Shank Diameter	Square Size	Square Length	No. of Flute	Tapping Drill Diameter
ØD1	P	X-coating	L1	L2	L3	ØD2	K	KI	Z	Ød1
M18 x 2.0		TRJ16666GS	26.0	125.0	50.0	14.0	11.0	14.0	3	16.0
M18 x 1.5		TRJ16676GS	25.0	110.0	44.0	14.0	11.0	14.0	3	16.5
M18 x 1.0		TRJ16686GS	20.0	110.0	44.0	14.0	11.0	14.0	3	17.0
M20 x 2.0		TRJ16716GS	27.0	140.0	54.0	16.0	12.0	15.0	3	18.0
M20 x 1.5		TRJ16726GS	25.0	125.0	50.0	16.0	12.0	15.0	3	18.5
M20 x 1.0		TRJ16736GS	20.0	125.0	50.0	16.0	12.0	15.0	3	19.0
M22 x 2.0		TRJ16756GS	27.0	140.0	54.0	18.0	14.5	17.0	3	20.0
M22 x 1.5		TRJ16766GS	25.0	125.0	50.0	18.0	14.5	17.0	3	20.5
M22 x 1.0		TRJ16776GS	20.0	125.0	50.0	18.0	14.5	17.0	3	21.0
M24 x 2.0		TRJ16796GS	27.0	140.0	54.0	18.0	14.5	17.0	3	22.0
M24 x 1.5		TRJ16806GS	27.0	140.0	54.0	18.0	14.5	17.0	3	22.5
M24 x 1.0		TRJ16816GS	20.0	140.0	54.0	18.0	14.5	17.0	3	23.0

◎ : Excellent ○ : Good

ISO Material Description	P										M				K					
	Non-alloy steel					Low alloy steel					High alloyed steel, and tool steel		Stainless steel		Grey cast iron	Nodular cast iron		Malleable cast iron		
VDI 3323	1	2	3	4	5	6	7	8	9	10	11	12	13	14	15	16	17	18	19	20
HRC	13	25	28	32	30	10	29	32	38	15	35	15	23	10	10	26	3	25	13	21
HB	125	190	250	270	300	180	275	300	350	200	325	200	240	180	180	260	160	250	130	230
Recommended	◎	◎	◎	◎	◎	◎	◎	◎	◎	◎	◎	◎	◎	◎	◎	◎	◎	◎	◎	◎

ISO Material Description	N										S						H				
	Aluminum-wrought alloy		Aluminum-cast, alloyed				Copper and Copper Alloys (Bronze / Brass)				Non Metallic Materials		Heat Resistant Super Alloys				Titanium Alloys		Hardened steel	Chilled Cast Iron	Hardened Cast Iron
VDI 3323	21	22	23	24	25	26	27	28	29	30	31	32	33	34	35	36	37	38	39	40	41
HRC	15	30	25	38	34	15	30	25	38	34	200	280	250	350	320	400Rm	1050Rm	550	630	400	550
HB	60	100	75	90	130	110	90	100													
Recommended	○	○	◎	◎	◎	◎	◎	◎													