

YG PIPE TAPS

TB514 SERIES

G(BSP) Whitworth pipe threads DIN ISO 228/1
 Whitworth Rohrgewinde DIN ISO 228/1
 G(BSP) PROFIL 55° DIN ISO 228/1
 Filettatura Whitworth per tubi DIN ISO 228/1
 Machine taps
 Maschinengewindebohrer

► Suitable for tapping blind holes due to special flute geometry and excellent chip evacuation.
 ► Geeignet zum Gewinden von Sacklöchern dank besonderer Nutengeometrie und ausgezeichneter Spanabfuhr.

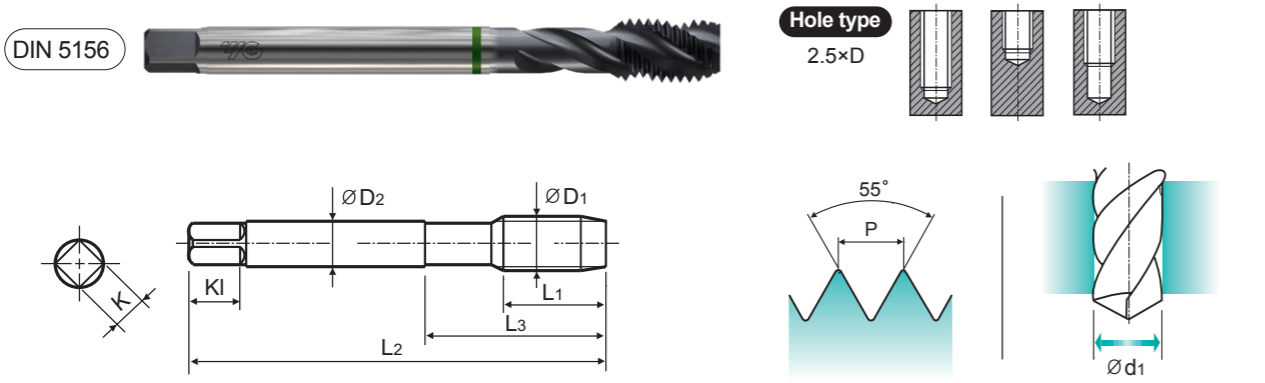

Material groups: **VA** **NW** **HSS-E** **DIN 5156** **55°** **C** **R40** **Vap** p.B314

Recommended ToolHolder: Plain Shank TAPPING ER CHUCK D215-220, TAPPING CHUCK D221-228, ONE STEP TAPPING CHUCK D211-213

Recommended Cutting Page : P.306 Unit : mm

SIZE	TPI	EDP No.	Thread Length	Overall Length	Neck Length	Shank Diameter	Square Size	Square Length	No. of Flute	Tapping Drill Diameter
ØD1		Vap	L1	L2	L3	ØD2	K	Kl	Z	Ød1
G1/8 - 28		TB514200	20	90	36	7	5.5	8	3	8.8
G1/4 - 19		TB514400	22	100	40	11	9	12	3	11.8
G3/8 - 19		TB514480	22	100	40	12	9	12	3	15.25
G1/2 - 14		TB514560	25	125	50	16	12	15	4	19
G3/4 - 14		TB514700	28	140	54	20	16	19	4	24.5
G1 - 11		TB514780	30	160	60	25	20	23	4	30.75

◎ : Excellent ○ : Good

ISO	P										M				K					
	Non-alloy steel					Low alloy steel					High alloyed steel, and tool steel		Stainless steel		Grey cast iron	Nodular cast iron		Malleable cast iron		
VDI 3323	1	2	3	4	5	6	7	8	9	10	11	12	13	14	15	16	17	18	19	20
HRc	13	25	28	32	38	10	29	32	38	15	35	15	23	10	10	26	3	25	21	
HB	125	190	250	270	300	180	275	300	350	200	325	200	240	180	180	260	160	250	130	230
Recommended	◎	◎								◎	◎	◎						◎	◎	

ISO	N					S					H										
	Aluminum-wrought alloy		Aluminum-cast, alloyed		Copper and Copper Alloys (Bronze / Brass)	Non Metallic Materials		Heat Resistant Super Alloys			Titanium Alloys		Hardened steel	Chilled Cast Iron	Hardened Cast Iron						
VDI 3323	21	22	23	24	25	26	27	28	29	30	31	32	33	34	35	36	37	38	39	40	41
HRc											15	30	25	38	34			55	60	42	55
HB	60	100	75	90	130	110	90	100			200	280	250	350	320	400Rm	1050Rm	550	630	400	550
Recommended	◎	◎	◎	◎	◎	◎	◎	◎			◎	◎	◎	◎	◎	◎	◎	◎	◎	◎	◎

YG PIPE TAPS

TC727 SERIES

G(BSP) Whitworth Pipe threads DIN ISO 228/1
 Whitworth Rohrgewinde DIN ISO 228/1
 G(BSP) PROFIL 55° DIN ISO 228/1
 Filettatura Whitworth per tubi DIN ISO 228/1
 Machine taps
 Maschinengewindebohrer

► Suitable for through hole in more cutting speed than other taps due to strong geometry.
 ► Geeignet für Sacklöcher in höherer Schnittgeschwindigkeit als andere Gewindebohrer dank einer stabilen Bohrergeometrie.

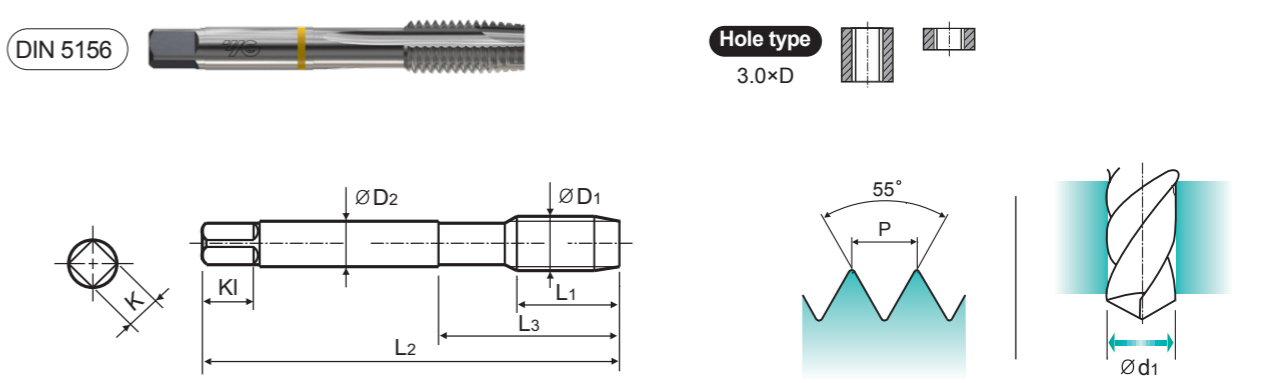

Material groups: **GS** **HSS-E** **DIN 5156** **55°** **B** **Bright** p.B314

Recommended ToolHolder: Plain Shank TAPPING ER CHUCK D215-220, TAPPING CHUCK D221-228, ONE STEP TAPPING CHUCK D211-213

Recommended Cutting Page : P.306 Unit : mm

SIZE	TPI	EDP No.	Thread Length	Overall Length	Neck Length	Shank Diameter	Square Size	Square Length	No. of Flute	Tapping Drill Diameter
ØD1		Bright	L1	L2	L3	ØD2	K	Kl	Z	Ød1
G1/8 - 28		TC727200	20	90	36	7	5.5	8	3	8.8
G1/4 - 19		TC727400	22	100	40	11	9	12	3	11.8
G3/8 - 19		TC727480	22	100	40	12	9	12	3	15.25
G1/2 - 14		TC727560	25	125	50	16	12	15	4	19
G3/4 - 14		TC727700	28	140	54	20	16	19	4	24.5
G1 - 11		TC727780	30	160	60	25	20	23	4	30.75

◎ : Excellent ○ : Good

ISO	P										M				K					
	Non-alloy steel					Low alloy steel					High alloyed steel, and tool steel		Stainless steel		Grey cast iron	Nodular cast iron		Malleable cast iron		
VDI 3323	1	2	3	4	5	6	7	8	9	10	11	12	13	14	15	16	17	18	19	20
HRc	13	25	28	32	38	10	29	32	38	15	35	15	23	10	10	26	3	25	21	
HB	125	190	250	270	300	180	275	300	350	200	325	200	240	180	180	260	160	250	130	230
Recommended	◎	◎	◎	◎	◎	◎	◎	◎	◎	◎	◎	◎	◎	◎	◎	◎	◎	◎	◎	◎

ISO	N					S					H										
	Aluminum-wrought alloy		Aluminum-cast, alloyed		Copper and Copper Alloys (Bronze / Brass)	Non Metallic Materials		Heat Resistant Super Alloys			Titanium Alloys		Hardened steel	Chilled Cast Iron	Hardened Cast Iron						
VDI 3323	21	22	23	24	25	26	27	28	29	30	31	32	33	34	35	36	37	38	39	40	41
HRc											15	30	25	38	34			55	60	42	55
HB	60	100	75	90	130	110	90	100			200	280	250	350	320	400Rm	1050Rm	550	630	400	550
Recommended	◎	◎	◎	◎	◎	◎	◎	◎			◎	◎	◎	◎	◎	◎	◎	◎	◎	◎	◎